



Ditec Sprint

Simply, all the comfort
that you have ever wanted

EN



3 GOOD REASONS

Beautiful

Lovely appearance, also ideal for more sophisticated environments.

Available in the plastic version, black or light grey, or in the Alu version, for high-class internal spaces, either in residential or office, studio, and hotel settings.



Simple

Easy to install, easy to use.

The reduced weight, optional battery and arrangement of the components enable a quick mechanical and electrical installation.



Modular

The modular line, for your every requirement.

You can choose the Alu cover or the plastic one. Additional choice of: 24 V DC power supply (without transformer) and 230 V AC versions are available and the battery is always optional.



Ditec Sprint



Automation for swing doors
Facilitates movement and improves quality of life

Beautiful. The new Ditec Spring automation, thanks to its neutral and elegant appearance is the ideal solution for both residential and high-class environments, such as professional studios, shops, offices and hotels.

Available in light grey, black or satin aluminium, it is suitable for internal swing doors up to 80 kg of weight.

Simple to assemble and install thanks to the lower weight fastening plate and the adjustments which can be set on the electronic card.

Simple to configure according to the choices and needs of its user thanks to the PUSH AND GO and LOW ENERGY modes.

Modular. It is possible to select the 24 V DC or 230 V AC power supply operator with the desired cover, the most suitable arm and add batteries, if required: the installers just have to select what they really need and if they wish they can integrate the selectors, the sensors and the other Ditec Entrematic accessories for a more complete installation.

Characteristics

Maximum capacity	80 kg x 1.0 m
Automation for swing doors	opening and closing by motor, with encoder
Service index	5 – heavy duty
Lifecycle	1,000,000 cycles
Protection rating	IP30, Class II (plastic version)
Temperature	-20 °C + 55 °C
Opening time	3 ÷ 6 s/90° (adjustable)
Closing time	4 ÷ 7 s/90° (adjustable)
Hold open time	30 s
Product dimensions (mm)	79x93x450

Main components

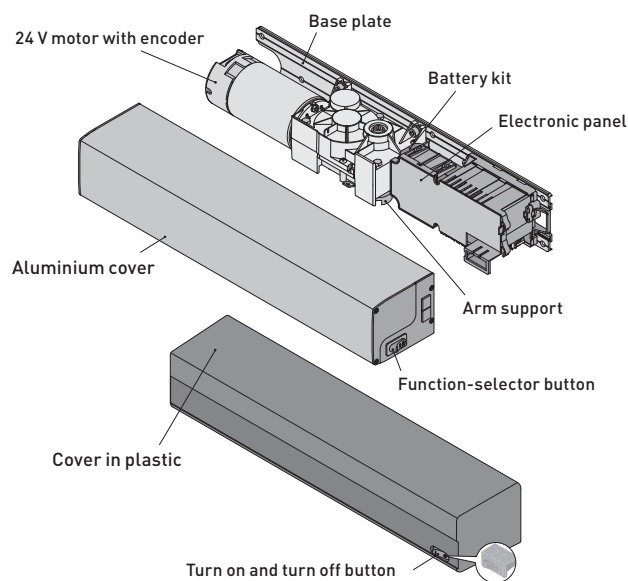

Product range

230 V AC power supply		
Description	Cover	Transformer
SPRINTV	aluminium	■
SPRINTP	light grey plastic	■
SPRINTPN	black plastic	■

24 V DC power supply	
Description	Cover
SPRINTLV	aluminium
SPRINTL	light grey plastic
SPRINTLN	black plastic

SPRINTV - SPRINTLV



SPRINTP - SPRINTL



SPRINTPN - SPRINTLN



Accessories

Movement arms

SBA
Arm with articulated motion.



Articulated - SBA

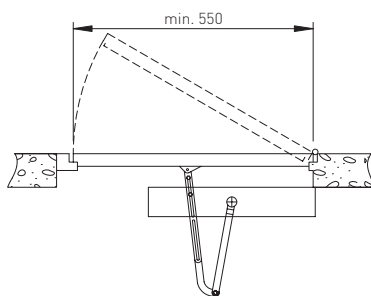

SPRINT BRAS
Arm with three-sections articulated motion for doors that open inward; automation seen from the side.



Articulated in three sections - BRAS

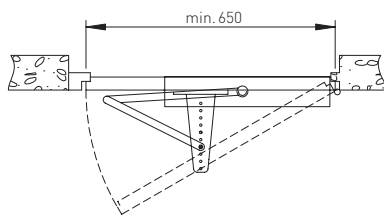

SBS
Arm with sliding motion.



Sliding - SBS

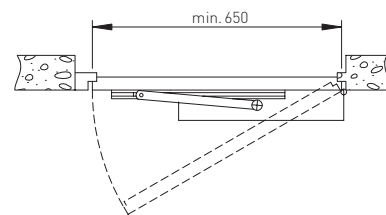

Specific accessories

- SPRINTBAT: battery kit
- SPRINTSET: memory card to rapidly set the automation

Control accessories and sensors

The automation can be completed with Ditec command, control and safety devices.

To select please refer to the PM general price list.

Certifications

MD
Machine Directive

EMCD
Compatibility Directive
Electromagnetic

LVD
Low Voltage Directive

EN 16005
User Safety Standard

When building the system, only use Ditec accessories and safety devices.

Every Ditec automation features CE marking and is designed and built in compliance with the safety requirements of the Machinery Directive (2006/42/EC), of the Electromagnetic Compatibility Directive (2004/108/EC) and of the Low Voltage Directive (2006/95/EC) and of other Directives, laws, specific standards for special products and situations.

The Company reserves the right to make changes which may improve the products.

For this reason, the technical details featured in this catalogue are not binding.

The pictures shown in this leaflet were taken with the consent of those concerned or in public locations.

Further information can be found in the Technical Manuals available at the website: www.ditecentrematic.com

Ditec
ENTRE//MATIC



Entrematic

Via Mons. Banfi, 3 • 21042 Caronno P.lla (VA) • Italy

Tel +39 02 963911 • Fax: +39 02 9650314

ditec@entrematic.com

www.ditecentrematic.com • www.entrematic.com

Cod. P202B - 11/2013
Ditec Sprint

gdp milano 147965

Ditec Entrematic branches are in: Belgium, France, Germany, Portugal, Spain, Sweden, Switzerland, Turkey, Latin America, USA, Canada and China.

For addresses and contacts visit our website www.ditecentrematic.com

